

PADDLE HANDLE PRODUCTS

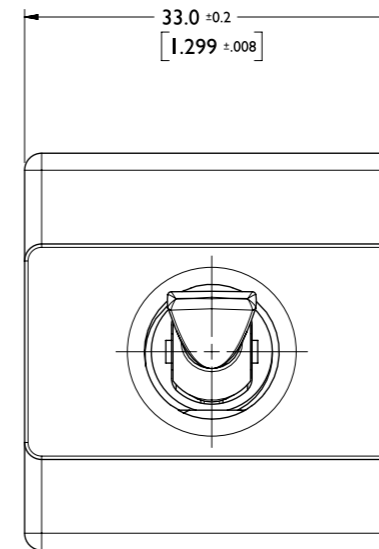
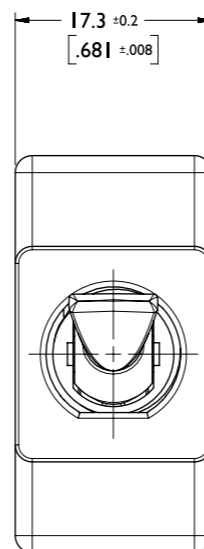
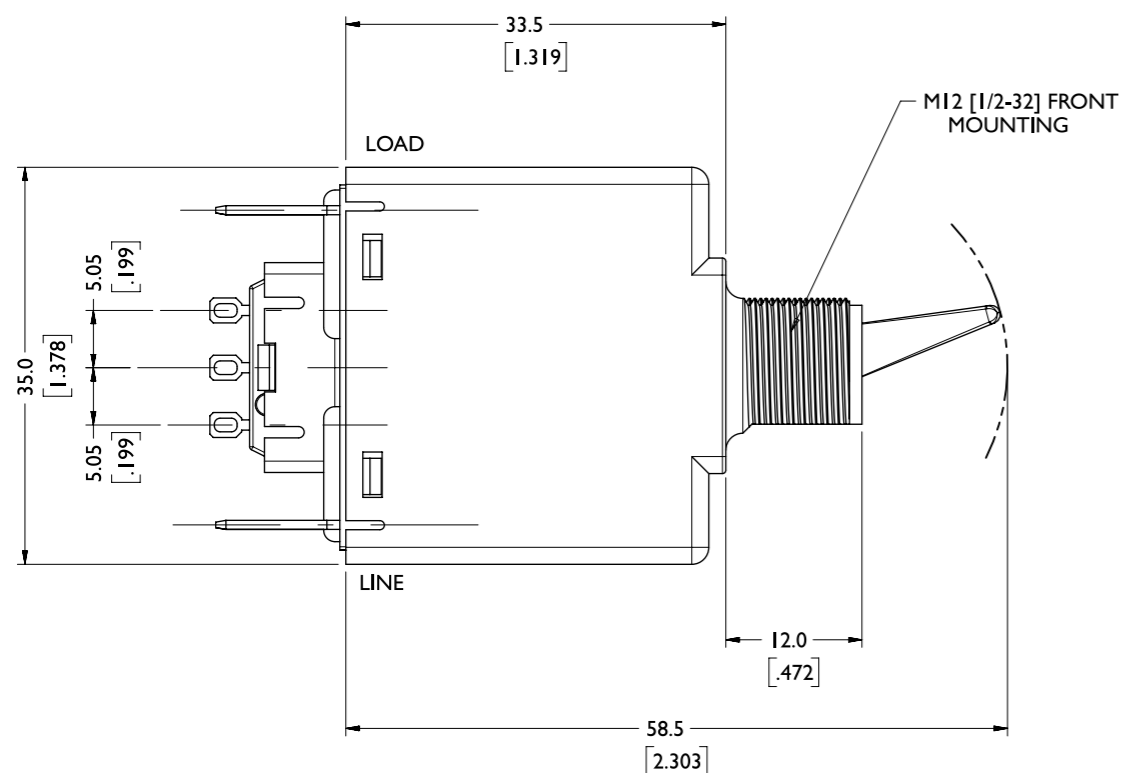

UNCONTROLLED

A	REFER TO PAGE 1 OF 10	CF
REV	DESCRIPTION	SIGN

MATING FACE	-MF
PROCESS DIMENSION	-PD
INTERSECTION	-INT
BEFORE PLATING	-BP
ALL DIMENSIONS IN	-mm
TOLERANCES ON UN-DIMENSIONED 90° FEATURES ARE ±0.5°	
TOLERANCES < ±0.1 ARE CRITICAL	
BRACKETED DIMENSIONS=EXISTING TOOLING	

SURFACE AREA	N/A	mm ²
VOLUME	N/A	mm ³
MATERIAL	N/A	
RAW MTL No.	N/A	
FINISH	N/A	

DRAWN	CF	DATE	29/09/2015
CHECK	APPD		
TOLERANCES	DO NOT SCALE		
X ±0.5	ORIGINAL SIZE A3		
X.X ±0.1			
X.XX ±0.05			
ANGULAR ±0.5°			

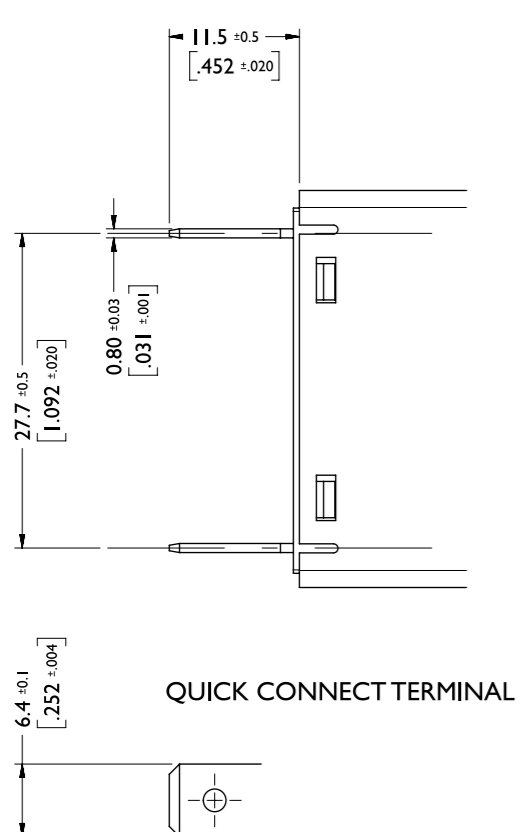

QUICK CONNECT TERMINAL

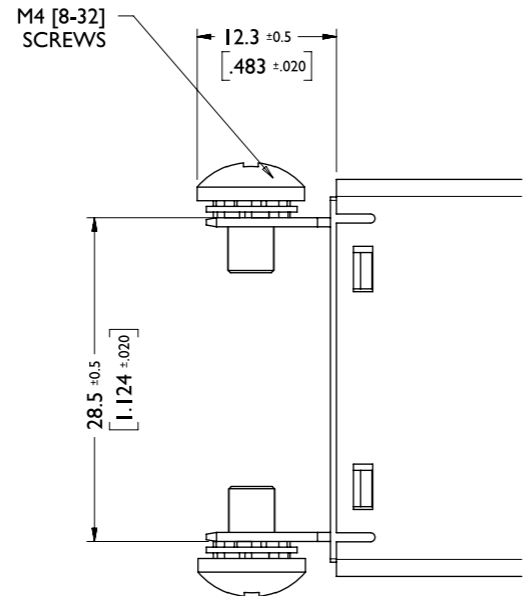

SCREW TERMINAL

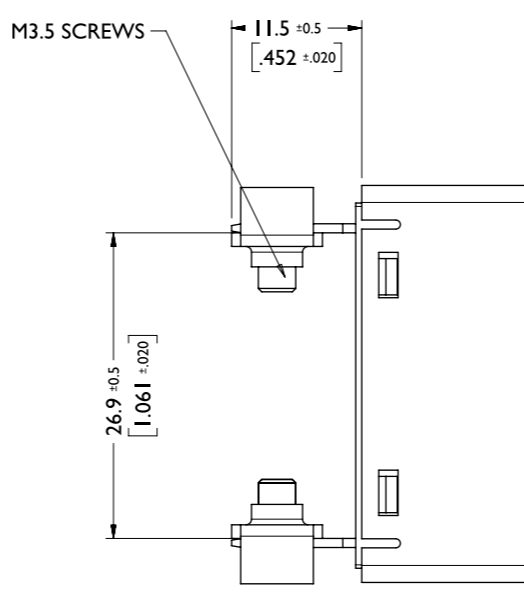

CLAMP TERMINAL

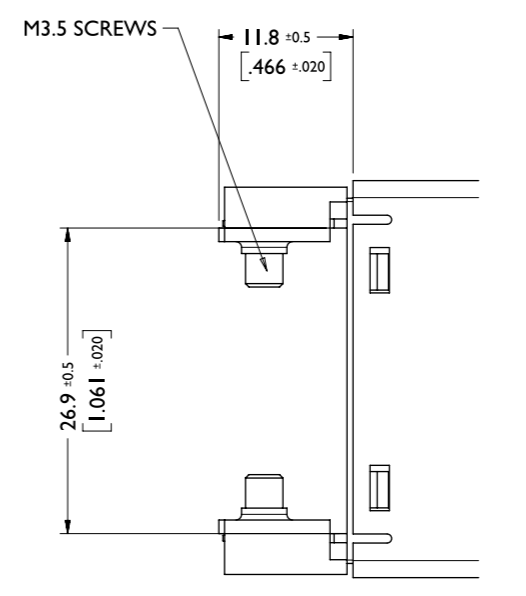

CLAMP TERMINAL (LONG)

MICRO SWITCH ONLY AVAILABLE WITH QUICK CONNECT TERMINALS

TOLERANCE ±0.4 UNLESS OTHERWISE SPECIFIED
(DIMENSION IN BRACKETS ARE IN INCH)

